

National History Day – California

2011 – 2012

Rule Book and Contest Guide



Coordinated by

Orange County Department of Education

<http://www.historydaycalifornia.org>



WILLIAM M. HABERMEHL
County Superintendent of Schools

Welcome to National History Day-California! By participating in this yearlong educational program, students don the three hats of the historian: the research hat, the analysis and interpretation hat, and the development and presentation hat. This Rule Book and Contest Guide emphasizes the development and presentation aspect of your NHD-California (NHD-CA) efforts. The rules contained in this document directly align with those of the National History Day program, ensuring that California’s state program expectations mirror and prepare students for participation at the national level.

You will select an entry category that allows you to make the best use of your research and project-development talents. Successful presentation of your thesis, analysis, and insights relies on compliance with the guidelines for the entry category you select. Be sure you know both the requirements for your specific entry category as well as the general requirements that apply to all entries. Read, become familiar with, and adhere to the rules (general and category) and suggestions within this Rule Book and Contest Guide to prepare your NHD-CA entry.

Learn more about the annual theme, topics and topic selection, sources, and deadlines from your district or county History Day coordinator or through a variety of valuable online program resources: the NHD-CA website at <http://www.historydaycalifornia.org> and the National History Day website at www.nhd.org.

You also may contact National History Day-California (NHD-CA) in writing, by phone, or via email as follows:

Address: 200 Kalmus Drive, Costa Mesa, CA 92626

Email: Participation and Program Information: Deborah Granger, Ed.D., NHD-CA State Program Director,
(714) 966-4447, dgranger@ocde.us

Table of Contents

Program Overview

A. Theme.....	2
B. Your Topic.....	2
C. Balanced Research.....	2
D. Annotated Bibliography.....	3
E. Participation in NHD-CA	4
F. Grade-Span Divisions.....	4
G. Entry Categories.....	4
H. Important Notices for Participants.....	4

Rules for All Categories

A. General Rules for All Categories	5
B. Rules Violations & Disqualification.....	7
C. Style Protocols & Citation Samples	8

Category Rules

A. Historical Paper Category Rules.....	9
B. Individual & Group Exhibit Rules.....	10
C. Individual & Group Performance Category Rules.....	12
D. Individual & Group Documentary Category Rules.....	13
E. Individual & Group Web Site Category Rules.....	15
F. Individual & Group 2-Dimensional Display Rules.....	17

Entry Judging

A. Who are the Judges?	18
B. How Does the Evaluation Process Work?.....	18
C. What are the Criteria?.....	19

State Finals Participation Guidelines

A. Registration Requirements.....	19
B. Competition Attendance.....	19

Program Overview

Theme

Each year a theme is selected for the National History Day program. Although you may select a topic on any aspect of local, regional, national, or world history, your project's research and conclusions must relate clearly to the annual theme. Be careful to limit the scope of your topic to focus on an issue that can be explained and interpreted within the category limits of size and time.

Your Topic

Once you are familiar with this year's theme, you will select a topic that relates to the theme. The California Framework and Content Standards for History-Social Science are available at www.cde.ca.gov. Remember to limit the scope of your topic to make your research, analysis, interpretation, and presentation manageable. History Day projects emphasize deep research and possibilities. To be considered "historical," a topic should be no less than twenty-five to thirty years old.

Effective National History Day entries not only describe an event or a development, but they also analyze and place it in its historical context. To help you draw conclusions about your topic's significance in history, ask yourself the following questions:

- How is my topic important in history?
- How was my topic significant in history in relation to the National History Day theme?
- How did my topic develop over time?
- How did my topic influence history?
- How did the events and atmosphere (social, economic, political, and cultural aspects) of my topic's time period influence my topic in history?
- What were the causes and effects of my topic?
- What are the differing perspectives/viewpoints on my topic?

Balanced Research

As young historians, you will conduct research that is balanced in three key ways: A) research that reflects a *variety of viewpoints* on your topic, B) research that reflects *different types of sources* (e.g., print, image & art, interview, broadcast, and/or online), and C) research that utilizes *primary and secondary sources*. Be sure to look for opposing viewpoints. Your job is to unravel differences in perspective, look for themes, and consider the context and how it influenced people in that time and place. While the Internet provides access to a tremendous wealth of information, historians also depend on interviews with eyewitnesses and documents and artifacts that are not available online. As you begin your research, you may rely on secondary sources that introduce you to your general topic. Primary sources however, will be what sets you apart as an historian.

National History Day describes **Primary Sources** as those written or produced in the time period you are investigating.

Primary sources include letters, speeches, diaries, newspaper articles from the time, oral history interviews of people from the time, documents, photographs, artifacts, and anything else that provides firsthand accounts about a person or event. This definition also applies to primary sources found on the Internet. A letter written by President Lincoln in 1862, whether scanned, transcribed, or otherwise reproduced, is a primary source for a student researching the Civil War era. A newspaper article about the Battle of Gettysburg written by a contemporary in July 1863 is a primary source.... The memories of a person who took part in the battle also can serve as a primary source because he or she was an eyewitness to and a participant in this historical event at the time. (NHD Contest Rule Book Revised 2010-2011, p. 5).

Identification of primary sources can become a bit tricky. For example, an article written in 2003 about the Montgomery Bus Boycott (1955-1956) by an author who was not an eyewitness or participant would not be a primary source unless the article was about 2003. Interviews with scholars and experts are extremely valuable, but are not primary sources unless those individuals lived through and have firsthand knowledge of the events being described. Exact reprints of the text of documents such as the U.S. Constitution in a secondary source such as a textbook can be considered primary sources if the purpose is to examine the *content* of the document. If however, you need to examine handwriting or something specific to the actual, physical document, the reprint will not serve as a primary source. **HEADLINE:** If there might be a question as to your designation of a source as primary or secondary, be sure to explain your rationale in your annotated bibliography.

Secondary Sources are developed by authors who were not eyewitnesses or participants in the historical event or era. These are "interpretations of primary sources, research, and study" (NHD Contest Rule Book Revised 2010-2011, p. 5). Typically, secondary sources provide context. "For example, high school history textbooks and history books about a particular topic are secondary sources; so are biographies, newspaper retrospectives, and reference books such as encyclopedias. This definition also applies to interpretations found on the Internet" (p. 5).

Tertiary Sources such as Wikipedia are not guaranteed to have been developed or scrutinized by scholars, experts, or eyewitnesses. These sources are not permitted in NHD projects at the state or national level.

Annotated Bibliography

The heart of every History Day entry is its annotated bibliography. Your “annotated bib” is divided into two key sections: A) Primary Sources, and B) Secondary Sources. Your sources must be listed as either primary or secondary - they may not be both simultaneously. This essential component of every NHD-CA entry reflects your understanding of the difference between primary and secondary sources, the depth of your research and the types of resources you used, and how you used the listed resources in developing your entry. While not required, some students develop sub-categories within each of the two key sections of their annotated bib. Examples of these sub-categories include Interviews, Periodicals, Documents, Images, etc.

You will list and describe only your use of the sources that contributed to the development of your entry. Your annotations are explanations of how you used your sources and how they helped you understand your topic. Your annotated bib indicates the level of knowledge you have about the critical sources associated with your topic. As with all written elements of your entry, your annotated bib must comply with current MLA or Turabian style protocols. Judges will look for consistent use of one protocol. As with any bibliography, the annotated bib includes essential information about the source including author, title, and publisher/publication information. Annotations about web sites should describe site sponsors (this helps you show the judges that you recognize the bias connected to each source). Different types of sources (e.g., books, magazines, web sites, etc.) have different citation specifications. Check the most current MLA or Turabian style guides for details. National History Day provides a sample annotation (Turabian style) for a book used as a primary source in its 2010-2011 Rule Book (p. 5):

Bates, Daisy. *The Long Shadow of Little Rock*. New York: David McKay, 1962. Print.

Daisy Bates was the president of the Arkansas NAACP and the one who met and listened to the students each day. This firsthand account was very important to my paper because it made me more aware of the feelings of the people involved.

Participation in NHD-CA

NHD-CA is a year-long education program with an opportunity to compete in an acclaimed academic contest. NHD-CA is open to all California students and teachers in grades 4 – 12 in public, private, and home school environments without regard to race, sex, religion, physical abilities, economic status, or sexual orientation. NHD-CA does not discriminate against or limit participation by physically challenged students. Our staff strives to accommodate students identified with special needs.

All NHD-CA contestants are recognized with certificates of participation. Additional special awards recognize outstanding effort and achievement. These vary from one year to the next. Students are apprised of special awards possibilities at registration time. As exciting as the contest is, the true rewards of NHD-CA participation come from your efforts, interest, and learning.

Participation in NHD-CA requires adherence to deadlines and registration requirements at each level of competition. While the general contest structure may involve classroom, school, district, and county competition before advancing to the State Finals, specifics may vary from one county to another. Rules at the county level may be somewhat different than those detailed in this Rule Book and Contest Guide. Please contact your local, district, or county History Day coordinator for information specific to your area.

Grade-Span Divisions

NHD-CA students compete in one of three grade-span divisions:

- Elementary Division : grades 4 & 5
- Junior Division: grades 6,7,& 8
- Senior Division: grades 9, 10, 11, & 12

Student entries are judged within grade-span divisions. Entries developed by fourth and fifth grade students will be judged alongside other entries submitted by students in these two grades. Because students may participate either as individuals or as members of a group, it is possible for a group to include any combination of students within a designated span of grades. Student entries are evaluated against others within a designated division, not by specific grade levels. For example, a Junior Division entry developed by a student in the sixth grade may be judged alongside an entry developed by a student in grade eight.

Entry Categories

Students participate in one of eleven entry categories:

- | | | |
|--------------------------------------|---|----------------------------------|
| 1. Paper (individual only) | } | Junior and Senior Divisions Only |
| 2. Individual Documentary | | |
| 3. Group Documentary | | |
| 4. Individual Exhibit | | |
| 5. Group Exhibit | | |
| 6. Individual Performance | | |
| 7. Group Performance | | |
| 8. Individual Web Site | | |
| 9. Group Web Site | | |
| 10. Individual 2-Dimensional Display | } | Elementary Division Only |
| 11. Group 2-Dimensional Display | | |

Each category in each grade-span division is judged separately. For example, individual exhibits will not be judged alongside group exhibits within the senior division.

Groups may include 2 – 5 students. Group members do not have to be in the same grade or class to compete together, but they must be in the same division.

While participation at the national level is limited to students in grades 6 – 12, California, along with a number of other states, provides an opportunity for students in grades four and five to participate in a unique category. The 2-Dimensional Display is a novice version of the Exhibit. The rules have been adjusted to meet the developmental level of our youngest participants. Champion entries in the Elementary Individual and Group 2-D Display category will not advance to National History Day held at the University of Maryland, as these categories and this division do not exist at the national level.

Important Notices for Participants

The NHD-CA contest is held in public areas. Participants are solely responsible for the security and safety of their own equipment and artifacts. The NHD-CA committees, program officials, volunteers, and sponsors will not be responsible for the loss of or damage to exhibits, props, equipment, or personal belongings.

Each county's NHD contest and system for advancing representatives to the State Finals is a little different. Please contact your county coordinator for details. If your county does not appear to have a coordinator, please contact NHD-CA for information on how to participate.

Rules for All Categories

NHD-CA rules are aligned with those of the national program. The following rules apply to every category. Participation in NHD-CA requires adherence to each of the following rules (Excerpted from NHD Contest Rule Book 2010-2011, pp. 8 – 11).

Rule 1: Annual Theme: Your entry must relate clearly to the annual theme and explain your topic's significance in history.

Rule 2: Contest Participation: You may participate in the research, preparation, and presentation of only one entry each year. You may share research only with up to four other students who are fellow participants in your group entry. You may not create a common pool of research from which several entries are created.

Rule 3: Individual or Group Entries: A paper, individual exhibit, individual performance, individual web site, individual documentary, or individual 2-D display must be the work of only one student. A group exhibit, group performance, group web site, group documentary, or group 2-D display must be the work of 2 to 5 students. All students in a group entry must be involved in the research and interpretation of the group's topic.

Rule 4: Development Requirements: Entries submitted for competition must be original and have been researched and developed in the current contest year. *Revising or reusing an entry from a previous year—whether it is yours or another student's - will result in disqualification.* The year begins each June, following the national contest and the announcement of the new theme.

Rule 5: Construction of Entry: You are responsible for the research, design, and creation of your entry. You may receive help and advice from teachers and parents on the mechanical aspects of creating your entry.

1. You may have help typing your paper and other written materials.
2. You may seek guidance from your teachers as you research and analyze your material, but your conclusions must be your own.
3. You may have photographs and slides commercially developed.
4. For your safety, you may have reasonable adult assistance operating machinery or equipment (e.g., power saw to cut out a prop you designed). If your project requires extensive direct adult assistance, consider another category that fits with what you can safely do yourself.

Rule 6: Contest Day Set-up: You are responsible for setting up your own exhibit, equipment, or props at the contest. You may have reasonable help carrying them, but set-up must be completed by you alone or, if applicable, you and your group members.

Rule 7: Equipment/Supplies: You are responsible for supplying all props and equipment at each level of competition. All entries should be constructed keeping transportation, set-up time, size, and weight in mind (e.g., foam core v. solid oak for an exhibit; folding table v. antique desk for a performance). DVD players and monitors or screens are available at the State Finals for the documentary category only. Internet access and computers are available for web site entry interviews. Tables are provided for exhibits and 2-D displays. You will provide any and all other supplies and equipment necessary for presenting your NHD-CA entry. Please contact your local/county coordinator for equipment details at that level of competition.

Rule 8: Discussion with Judges: You should be prepared to respond to judges' questions about the content and development of your entry. You will not give a formal, prepared introduction, narration, or conclusion. Let the judges' questions guide the interview. Ultimately, your entry should be able to stand on its own without any additional comments from you. You should be prepared to explain the design, research, and creation of your entry if questioned by the judges. Judges need to know that your entry is the result of your own work.

Rule 9: Costumes: Only participants in the performance category may wear costumes related to the focus of their entry.

Rule 10: Prohibited Materials: Items potentially dangerous in any way—such as weapons, firearms, animals, organisms, plants, etc. - are strictly prohibited. Such items will be confiscated by security personnel or contest officials and may result in disqualification. Replicas of such items that are obviously not real are permissible. Please contact your teacher and contest coordinator to confirm guidelines before bringing the replica to a contest.

Rule 11: Title: Your entry must have a title that is clearly visible on all written materials.

Rule 12: Written Material: Your entry must include the following written material *in the order presented below*:

1. Title page as described in Rule 13
2. Process paper as described in Rule 14 (process papers are not part of historical paper entries)
3. Annotated bibliography as described in Rule 15

These materials must be typed or neatly printed on plain white paper, and stapled together in the top left corner. Do not enclose them in a cover or binder. You must provide four copies of these materials, except in the Historical Paper and Web Site categories. Students submitting Web Site entries must integrate these required "written" materials into the site. Historical Paper entries include the title

page and annotated bibliography only. These entries are submitted electronically – a paper copy is recommended but not required in the Paper category.

Rule 13: Title Page: A title page is required as the first page of written material in every category. Your title page must include only the title of your entry, your name(s), and the contest division and category in which you are entered. The home page of Web Site entries may serve as the title page – in this case, navigation buttons, images, music, etc. are acceptable.

Rule 14: Process Paper: All categories except Historical Paper must include a process paper with the entry. It must describe in 500 words or less how you conducted your research and created your entry. The process paper must include four sections that explain:

1. how you chose your topic
2. how you conducted your research
3. how you selected your presentation category and created your project
4. how your project relates to the NHD theme

You can view sample process papers at www.nhd.org on the “Creating an Entry” page in the Contest section.

Rule 15: Annotated Bibliography: An annotated bibliography is required for all categories. You are required to separate your bibliography into primary and secondary sources. List only those sources that contributed to the development of your entry, sources that provided usable information or new perspectives in preparing your entry. You likely will include fewer sources than you actually used. Sources of visual materials and oral interviews must be included. The annotations for each source must explain how you used the source and how it helped you understand your topic. Annotations of web sites should describe who sponsors the site. More information about the annotated bibliography is available on page eight of this document.

Rule 16: MLA and Turabian Style: Formatting and style conventions for written materials including citations and bibliographic references must follow the principles in a recent edition of one of the following style guides.

1. Kate L. Turabian, *A Manual for Writers of Term Papers, Theses, and Dissertations*
2. Joseph Gibaldi, *MLA Handbook for Writers of Research Papers*

Regardless of which manual or style convention you use, the style must be consistent throughout all written material.

Rule 17: Plagiarism: You must acknowledge in your annotated bibliography all sources used in your entry. *Failure to credit sources is plagiarism and will result in disqualification.*

Rule 18: Registration: You must meet registration deadlines and procedures established by the contest coordinator at each level of competition in order to participate. NHD-CA uses an online registration system. Registration announcements will be made by February to county coordinators.

Rule 19: Attendance at the State Finals: All individual competitors and group members must be present at the state contest to be eligible for entry evaluation. Replacements are not permitted. This rule also applies as students advance to the National Finals.

Rule 20: Sharing Entries: Your registration in the NHD-CA State Finals indicates that you grant permission for contest officials to duplicate, publish, distribute, and/or display your work to support program growth and excellence in California.

Rules Violations and Disqualification

While we do not like to think about the possibility that rules might be violated, it is important to note that most rules violations will not result in the disqualification of a NHD-CA entry. However, three rules violations will result in disqualification of an entry:

1. Plagiarism
2. Use of another entry as your own, and/or
3. Reuse of an entry from a previous year

All other rules violations are factored into the judging process. The violation is weighed against the quality of the entry and the significance of the violation. For example, omission of an annotated bibliography will result in an extremely low entry ranking while a process paper that is 10 words over the word limit is much less significant. Adhering to the rules makes your entry a contender in a highly competitive contest.

Plagiarism is the use of another's text, ideas, or products in such a fashion that the text, ideas, or products appear to be your own. When you quote or paraphrase another's words or ideas, and/or use a photograph or other image created by someone else, be sure to cite the source where you use it (e.g., in footnotes) and include it in your annotated bibliography.

Many individuals mistakenly believe that the ability to pluck images and text from the Internet makes it legal. Easy access (or difficult access for that matter) does not equate legal copying and use. Be sure you understand copyright provisions, cite sources appropriately, and secure written permission from the copyright owner(s) as needed.

United States Copyright Law protects original works such as writings, music, motion pictures, videos, photographs, and illustrations. In general, copyright law forbids the use of such material without the permission of the person or entity owning the copyright. If a student entry uses such materials, the student is responsible for providing appropriate citations and securing written permission from the copyright owner.

However, students may make "fair use" of copyrighted materials for the purposes of criticism, scholarship, or research. To determine whether the use of copyrighted material is a "fair use" requires the weighing and balancing of various factors:

- 1) the purpose and character of the use, including whether such use is of a commercial nature or is for nonprofit educational purposes
- 2) the nature of the copyrighted work (creative works are afforded greater protection than factual works)
- 3) the amount and substantiality of the portion used in relation to the copyrighted work as a whole
- 4) the effect of the use upon the potential market for the value of the copyrighted work. The fact that a work is unpublished shall not itself bar a finding of "fair use" if such finding is made upon consideration of all the above factors

U.S. Code Title 17, Section 107

Legal analysis of "fair use" is complicated. Lack of clear precedents makes it extremely difficult to provide much advice beyond recommendations to limit the use of copyrighted material and/or obtain written permission from the owner(s) of the copyright(s).

Style Protocols & Citation Samples

The samples below are based on the Turabian and MLA style guides. The source (e.g., book, periodical, online magazine, etc.) determines the specifics of the citation. Please refer to a current edition either the Turabian or MLA style guide for specifics for the many types of sources you are bound to include in your annotated bibliography.

MLA Style Citation Samples

Book by a Single Author (annotation included)

Berkovits Gross, Elly. Elly: My True Story of the Holocaust. New York: Scholastic Inc., 2007.

This is the biography of a girl from Romania who was deported to a concentration camp at 15 years old. Her tale helped me to realize the danger that Irena experienced and the horror she delivered her children from.

Newspaper Article (unsigned)

"Death of a President." Editorial. New York Times 20 Apr. 1984, late ed.: A18.

Newspaper Article (signed)

Barrow, Matthew. "Skipping School? Start Walking." Sacramento Bee. 13 Oct. 1999, California final ed.: A1+.

Online Encyclopedia Entry

"Algeria." Encyclopedia Britannica Online. Vers. 97.1.1. Mar. 1997. Encyclopedia.

Email Message

Franson, Paul. "Resolving Game Disputes." E-mail to the author. 2 July 2007.

Turabian Style Citation Samples

Book by a Single Author (annotation included)

Berkovitz Gross, Elly. *Elly: My True Story of the Holocaust*. New York: Scholastic, Inc., 2007.

This is the biography of a girl from Romania who was deported to a concentration camp at 15 years old. Her tale helped me to realize the danger that Irena experienced and the horror she delivered her children from.

Newspaper Article (unsigned)

"Profile of Apple, Inc." *Silicon Valley Times*, 21 January 1999, sec. III, p. 5.

Newspaper Article (signed)

Dial, Mark. "Mule Deer Poised to Make a Comeback: Opponents Fear Ravaged Crops; Advocates Fear for the Deer." *New York Post*, 13 May 2001, sec. F, p. 1, 4.

Online Encyclopedia Article

"King, Martin Luther, Jr." Encyclopaedia Britannica [encyclopedia online](Britannica.com Inc., 1999); available from <http://www.britannica.com> (Accessed 2 February 2003).

Email Message

Artemis, Rebecca. "Mea Culpa: Citing Sources." Personal e-mail (12 Feb. 2004).

Category Rules – Historical Paper (HPA)

A paper is the traditional form of presenting historical research. Various types of creative writing (for example, fictional diaries, poems, etc.) are permitted, but must conform to all general and category rules. Your Historical Paper should be grammatically correct and well written.

Rules for All Categories apply to the Historical Paper category with the exception of Rule 14. Historical Paper entries do not require a process paper.

Rule HPA-1: Length Requirements: The text of historical papers must be no less than 1,500 and no more than 2,500 words in length. Each word or number in the text of the paper counts as one word. The 2,500-word limit does not apply to notes, annotated bibliography, illustration captions, and supplemental/appendix material. Appendix material must be referred to in the text of the paper. Extensive supplemental materials are inappropriate. Use of appendices should be very limited and may include photographs, maps, charts, and graphs, but no other supplemental materials. Transcripts, correspondence, questionnaires, and other sources should be cited in your annotated bibliography but not included as attachments to your paper.

Rule HPA-2: Citations: Citations—footnotes, endnotes, or internal documentation—are required. Citations are used to credit the sources of specific ideas as well as direct quotations. Please note that an extensively annotated footnote should not be used to get around the word limit.

Rule HPA-3: Preparation Requirement: Papers must be typed, computer printed, or legibly handwritten in ink on plain, white 8.5 x 11-inch paper with 1-inch margins on all sides. Pages must be numbered consecutively beginning with the first page following the title page (do not number the title page), and double-spaced with writing on one side and with no more than 12 characters per inch or no less than 10-point type.

Rule HPA-4: Entry Submission: Your final Historical Paper and annotated bibliography, saved as one document, preferably in PDF format to preserve your formatting and protect against changes, must be submitted **via e-mail** by the established contest deadline (check the National History Day - California web page at <http://www.historydaycalifornia.org> for more details). Utilize the following saving convention:

Last Name_First Name_Division_2012.pdf (example: Rodriguez_Jane_Senior_2012.pdf).

Note that the deadline for submission of Historical Papers is usually set for a date well in advance of the competition so that judges will have time to thoroughly read and evaluate your work. *It is **recommended** that you bring a hard copy of your final Historical Paper* (stapled in the top left corner and **not** be enclosed in any cover or binder) *to the competition.*

Historical Paper Checklist

- ✓ 1,500 – 2,500 words, excluding notes, annotated bibliography, and title page
- ✓ Title page includes title of entry, name, division (Junior or Senior), and category (Historical Paper) only
- ✓ Annotated bibliography, separated into primary and secondary sources
- ✓ Clearly links topic to theme and demonstrates exploration of the entire theme
- ✓ Demonstrates significance of topic in history
- ✓ Citations provided within the body of the paper
- ✓ Submitted via e-mail by established contest deadline
- ✓ Demonstrates wide and balanced research and use of primary sources
- ✓ Historically accurate
- ✓ Shows interpretation and analysis
- ✓ Places topic in historical context
- ✓ Presentation of topic is creative, original, and well organized
- ✓ Has followed copyright laws

Category Rules – Individual and Group Exhibit (EXH)

Individual Exhibits are judged alongside other Individual Exhibits within the same grade-span division as are Group Exhibits.

An exhibit is a visual representation of your research and interpretation of your topic's significance in history, much like a *small museum exhibit*. The analysis and interpretation of your topic must be clear and evident to the viewer. Labels and captions should be used creatively with visual images and objects to enhance the message of your exhibit.

In addition to the rules below, Rules for All Categories apply to exhibits.

Rule EXH-1: Size Requirements: The overall size of your exhibit when displayed for judging must be no larger than 40 inches wide, 30 inches deep, and 6 feet high. Measurement of the exhibit does not include the table on which it rests; however, it would include any stand that you create and any table drapes. Circular or rotating exhibits or those meant to be viewed from all sides must be no more than 30 inches in diameter. (See diagram below.)

Rule EXH-2: Media Devices: Media devices (e.g., DVD players, projectors, video monitors, computers) used in an exhibit must not run for more than a total of 3 minutes and are subject to the 500-word limit (Rule EX3). Viewers and judges must be able to control media devices. Any media devices must fit within the size limits of the exhibit. Any media devices used should be integral to the exhibit—not a method to bypass the prohibition against live student involvement. For example, a brief excerpt from a taped student-conducted oral interview or a dramatic reading is appropriate, but taped commentary or analysis is inappropriate.

Rule EXH-3: Word Limit: A 500-word limit applies to all text created by the student that appears on, or as part of, an exhibit entry. This includes the text you write for titles, subtitles, captions, graphs, timelines, media devices (e.g., video, slides, computer files), or supplemental materials (e.g., photo albums, scrapbooks, etc.) where you use your own words. Brief citations crediting the sources of illustrations or quotations included on the exhibit do not count toward the 500-word limit.

NOTE: A date counts as one word, while each word in a name is individually counted. For example, January 1, 1900 counts as one word, but John Quincy Adams counts as three. Words such as "a," "the," and "of" are counted as one word each.

NOTE: Be careful that your message is clear and contained on the exhibit itself; judges have little time to review supplemental material. Extensive supplemental material is inappropriate. For example, oral history transcripts, correspondence between you and experts, questionnaires, and other primary or secondary materials used as sources for your exhibit should be cited in your bibliography but not included as attachments to your bibliography or exhibit.

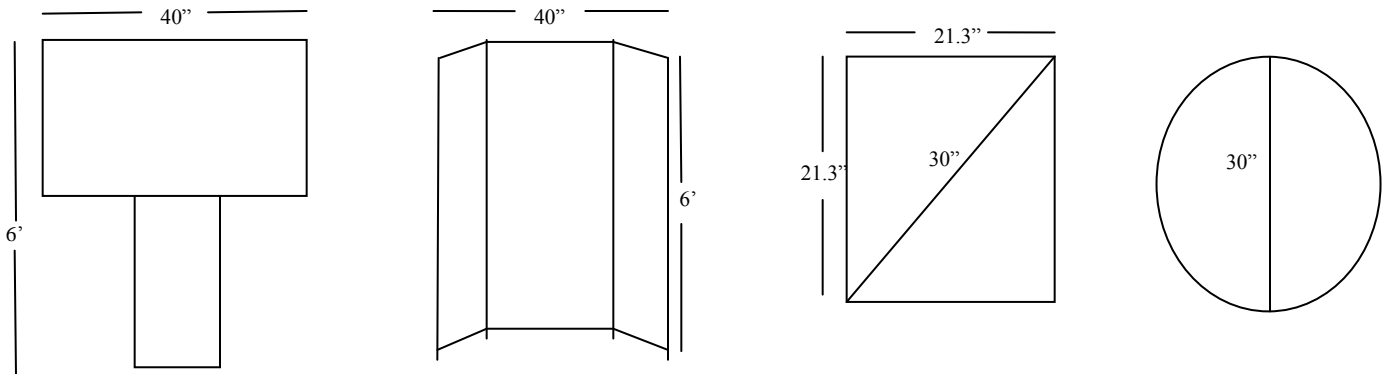

Exhibit Checklist

- ✓ No larger than 40 inches wide, 30 inches deep, and 6 feet high when displayed
- ✓ Clear and visible title
- ✓ Minimum of 4 copies (plus one for yourself) of written materials
 - Title page with entry title, name(s), division (Junior or Senior), and category (Exhibit) ONLY
 - Process paper no longer than 500 words
 - Annotated bibliography separated into primary and secondary source sections
 - Stapled at top left corner
- ✓ Shows wide research and use of primary sources
- ✓ Provides evidence of balanced research (multiple perspectives)
- ✓ Clearly links topic to theme and demonstrates exploration of the entire theme
- ✓ No more than 500 student-composed words (includes labels, captions, and titles)
- ✓ Sources of quotations and illustrations, etc. are credited with brief citations on the exhibit
- ✓ Historically accurate
- ✓ Shows interpretation and analysis
- ✓ Places topic in historical context
- ✓ Demonstrates significance of topic in history
- ✓ Presentation of topic is creative, original, and well organized
- ✓ Has visual impact and shows interpretation
- ✓ You must set up your exhibit; adults may assist you in *carrying* heavy or oversized items only
- ✓ Has followed copyright laws

Category Rules - Individual and Group Performance (PER)

A performance is a dramatic portrayal of your topic's significance in history and must be original in production. It must be scripted by you based on research of your chosen topic. Your performance should have dramatic appeal, but not at the expense of historical information.

In addition to the rules below, Rules for All Categories apply to performances.

Rule PER-1: Time Requirements: Performances may not exceed 10 minutes in length. Timing starts at the beginning of the performance following the announcement of the title and student name(s). Any other introductory remarks will be considered part of the performance and will be counted as part of the overall time. You will be allowed an additional 5 minutes to set up and 5 minutes to remove any props needed for your performance.

NOTE: You should allow several empty seconds in your performance to account for unplanned pauses (e.g., applause, forgotten lines, etc.).

Rule PER-2: Performance Introduction: The title of your entry and the names of the participants must be the first and only announcements prior to the start of the performance.

Rule PER-3: Media Devices: Use of slides, tape recorders, computers, or other media within your performance is permitted. You must provide and run all equipment, as well as carry out any special lighting or sound effects.

Rule PER-4: Script: The script for the performance should *not* be included with the written material presented to the judges.

Rule PER-5: Costumes: You may have a costume produced for you, but the design, choice of fabrics, etc., must be your own. Or, you may rent a costume. Remember: simple is best.

Performance Checklist

- ✓ Performance does not exceed 10 minutes in length
- ✓ Set up and removal of props do not exceed 5 minutes for each
- ✓ Minimum of 4 copies (plus one for yourself) of written materials
 - Title page with entry title, name(s), division (Junior or Senior), and category (Performance) ONLY
 - Process paper no longer than 500 words
 - Annotated bibliography separated into primary and secondary source sections
 - Stapled at top left corner
- ✓ Any props, equipment, and costumes are student supplied
- ✓ Students registered for the given performance are the only individuals who may set up props, run equipment, or otherwise participate in the performance.
- ✓ Shows wide research and use of primary sources
- ✓ Provides evidence of balanced research (multiple perspectives)
- ✓ Historically accurate
- ✓ Shows interpretation and analysis
- ✓ Places topic in historical context
- ✓ Clearly links topic to theme and demonstrates exploration of the entire theme
- ✓ Demonstrates significance of topic in history
- ✓ Presentation of topic is creative, original, and well organized
- ✓ Has followed copyright laws

Category Rules - Individual and Group Documentary (DOC)

A documentary should reflect your ability to use audiovisual equipment to communicate your topic's significance, much as professional documentarians do. The documentary category will help you develop skills in using photographs, film, video, audiotapes, computers, and graphic presentations. Your presentation should include primary source materials and also must be an original production. To produce a documentary you must have access to equipment and be able to operate it.

In addition to the specific rules below, Rules for All Categories apply to documentaries.

Rule DOC-1: Time Requirements: Documentaries may not exceed 10 minutes in length. You will be allowed an additional 5 minutes to set up and 5 minutes to remove equipment. Timing will begin when the first visual image of the presentation appears and/or the first sound is heard. Audio and visual leads will be counted in the time limit. Timing will end when the last visual image or sound of the presentation concludes (including credits).

NOTE: Use your set-up time to prepare your documentary for presentation, focus equipment, adjust volume, etc.

NOTE: Avoid going over the time limit by anticipating unplanned pauses – lead time on DVDs, mechanical challenges, etc.

Rule DOC-2: Introduction: You must announce only the title of your presentation and names of participants. Comments prior to or during the presentation, including live narration, are prohibited.

Rule DOC-3: Student Involvement: You are responsible for running all equipment.

Rule DOC-4: Student Production: All entries must be student-produced. You must operate all equipment. You must provide the narration, voice-over, and dramatization. Only those students listed as entrants may participate in the production. Only entrants and the subjects of their interviews (participants in an historical event or experts) may appear on camera.

Rule DOC-5: Entry Production: Your entry must be an original production. You may use professional photographs, film, slides, recorded music, etc., within your presentation. However, you must integrate such items into your presentation and give proper credit at the end of your presentation as well as in your annotated bibliography. You must operate all editing equipment used in the production of your presentation. Using material created by others specifically for use in your entry violates this rule.

NOTE: Remember that different equipment may affect how your documentary appears on the screen. You may wish to test equipment provided at competitions beforehand, bring back-up copies of your documentary in different formats, and/or bring your own equipment. There is no penalty for displaying your documentary on a laptop computer and many students use them successfully as a backup measure.

Rule DOC-6: Credits: At the conclusion of the documentary, you must provide a list of acknowledgments and credits for all sources. These credits should be brief - not full bibliographic citations and not annotated. All sources (music, images, film/media clips, interviews, books, web sites) used in the making of the documentary should be properly cited in the annotated bibliography. The list of credits counts toward the 10-minute time limit and should be readable by viewers.

Rule DOC-7: Displays: Stand alone displays are not part of this category and are prohibited.

Rule DOC-8: Computer Entries: You must be able to run the program within the 10-minute time limit. Interactive computer programs and web pages in which the audience or judges are asked to participate are not acceptable; judges are not permitted to operate any equipment. Students must provide and be able to run their own computers, software, and other equipment. Internet access will not be available.

Special Note and Support Information on DVD Entries

Students are expected to bring their documentaries on DVD to play them for judges at the contest. NHD-CA makes every effort to support students in presenting their documentaries for judges to evaluate. At the NHD-CA State Finals, **each Documentary judging room will be outfitted with a computer with a DVD player as well as a monitor or screen.** To support students' efforts to be prepared for a successful judging experience, we offer the following recommendations:

- **Come Prepared:**
 - **As a backup, bring the computer on which the documentary was developed. By also bringing any necessary projector connector (especially important for Mac users), you increase the possibility of your project being projected onto a screen (if one is available).**
 - (At least as a backup) **Save your project as a Quicktime video** to make it more universally accessible.
 - **Save your project on both a flash drive as well as on DVD.**
 - **Test your DVDs!** We cannot emphasize this enough! Test each of your DVDs on at least TWO stand-alone DVD players IN ADDITION to the computer you plan to bring to the contest to check for video and audio quality and stability.
 - **Make and bring several copies** of tested DVDs.
 - **While we cannot recommend posting documentaries to the Internet, if you happen to do so, bring the link.**
- **Recommendations for writing/burning your documentary onto DVD:**
 1. Use WRITE-ONCE DVD media (e.g., DVD+R and/or DVD-R). Not all DVD players recognize re-writable media (i.e., +RW and -RW).
 2. If your DVD writing software permits, change the *BookType* (also known as bitsetting) from DVD-R to DVD-ROM. Some writing software automatically does this. Your software or device manual can provide you with the necessary technical information. BookType and Bitsetting apply only to DVD+R media.
 3. Write slowly! By writing the DVD at a slower speed, you increase stability. If your DVD writer supports 16x media, write at 12x or 8x. Writing at maximum speed can generate errors.
 4. Labels may cause your DVD to rotate unevenly in the DVD player. Use a Sharpie® pen or a Lightscribe burner to identify your DVDs.
 5. Single-task when writing to a DVD. Close out any other tasks that may be running in the background of your workstation.

Documentary Checklist

- ✓ Presentation does not exceed 10 minutes
- ✓ Set up and removal do not exceed 5 minutes for each
- ✓ Participant involvement during the presentation entails operating equipment, providing judges with written materials, and announcing name(s) and title
- ✓ Minimum of 4 copies (plus one for yourself) of written materials
 - Title page with entry title, name(s), division (Junior or Senior), and category (Performance) ONLY
 - Paper no longer than 500 words
 - Annotated bibliography separated into primary and secondary source sections
 - Stapled at top left corner
- ✓ Shows wide research and use of primary sources
- ✓ Provides evidence of balanced research (multiple perspectives)
- ✓ Historically accurate
- ✓ Shows interpretation and analysis
- ✓ Places topic in historical context
- ✓ Clearly links topic to theme and demonstrates exploration of the entire theme
- ✓ Demonstrates significance of topic in history
- ✓ Presentation of topic is creative, original, and well organized
- ✓ Has followed copyright laws
- ✓ Has back-up copies of DVD &/or other necessary equipment (as appropriate)

Category Rules - Individual and Group Web Site (WEB)

The web site category is the most interactive of all NHD categories. By developing a collection of web pages, connected by hyperlinks, you create a self-guided experience for the viewer that demonstrates your interpretation of the topic and theme. Inspired by rich interpretative and interactive web sites, such as sites hosted by the Smithsonian, entries in this category should include primary and secondary sources, interactive multimedia, and historical analysis. It should incorporate textual and non-textual photographs, maps, music, etc.) descriptions, interpretations, and sources to engage and inform viewers. All web site entries **MUST** be developed using the NHD online web site editor. You will access this through the NHD web site at www.nhd.org. This category reflects your ability to use web site design software and computer technology to communicate the topic's significance in history. To construct a web site project, you must be able to operate, and have access to, the Internet, appropriate software, and equipment.

NOTE: Be sure to balance your research with non-Internet sources.

In addition to the rules below, Rules for All Categories apply to web sites.

Rule WEB-1: Entry Production: All entries must be original productions constructed using the online NHD web site editor beginning at the school level. You may use professional photographs, graphics, video, recorded music, etc., within the site. Such items must be integrated into the web site, and proper credit must be given within the site as well as in the annotated bibliography. You must operate all software and equipment in the development of the web site.

NOTE: Using objects created by others for specific use in your entry violates this rule. For example, using a graphic that others produced at your request is not permitted; however, using graphics, multimedia clips, etc., that already exist is acceptable.

Rule WEB-2: Size Requirements: Web site entries may contain no more than 1,200 visible, student-composed words. Code used to build the site and alternate text tags on images do not count toward the word limit. Also excluded are: words found in materials used for identifying illustrations or used to briefly credit the sources of illustrations and quotations; recurring menus, titles, and navigation instructions; words within primary documents and artifacts; and the annotated bibliography and process paper that must be integrated into the site. The entire site, including all multimedia, the process paper, and annotated bibliography, may use no more than 100MB of file space.

Rule WEB-3: Navigation: One page of the web site must serve as the "home page." The home page must include the names of participants, entry title, division, and the main menu that directs viewers to the various sections of the site. All pages must be interconnected with hypertext links. Automatic redirects are not permitted.

Rule WEB-4: Multimedia: Each multimedia clip may not last more than 45 seconds. You may record quotes and primary source materials for dramatic effect, but you may not narrate your own compositions or other explanatory material. All multimedia must be stored within the site; you may not use embedded material hosted elsewhere (e.g., YouTube, Google Video). There is no limit to the number of multimedia clips you may use, but you must respect the file size limit. If you use any form of multimedia that requires specific software to view (e.g., Flash, QuickTime, Real Player), you must provide on the same page a link to an Internet site where the software is available as a free, secure, and legal download. Judges will make every effort to view all multimedia content, but files that cannot be viewed cannot be evaluated as part of the entry.

Rule WEB-5: Required Written Materials: The annotated bibliography and process paper must be included as an integrated part of the web site. They should be included in the navigational structure. They do **NOT** count toward the 1,200 student-composed word limit. You will follow the general rules regarding citations and style (see Rules 15 & 16) for the written materials integrated into your Web Site project.

Rule WEB-6: Stable Content: The content and appearance of a page cannot change when the page is refreshed in the browser. Random text or image generators are not allowed.

Rule WEB-7: Viewing Files: The pages that comprise the site must be viewable in a recent version of a standard web browser (e.g., Microsoft Internet Explorer, Firefox, Safari). You are responsible for ensuring that your entry is viewable in multiple web browsers. Entries may not link to live or external sites, except to direct viewers to software plug-ins, per Rule WEB-4.

Rule WEB-8: Submitting Entry for Judging: You must submit the URL for the site in advance by the established deadline, after which you will be blocked from editing your site to permit equitable judging. All required written materials are integrated into the site. **NO** printed copies are required. Please visit the ca.nhd.org for this year's timeline and web site block date. Check with your county coordinator for deadlines at that level. While not required, it is recommended that you bring a printout of your website, including your annotated bibliography and process paper, to the competition.

Web Site Check List

- ✓ Site contains no more than 1,200 student generated words
- ✓ Adheres to the 100 MB size limit
- ✓ Adheres to the 45 second limit per multimedia component with no student narration
- ✓ Constructed using the NHD web site editor beginning at the school level
- ✓ Does not include live or external links (except for software downloads needed to view site)
- ✓ Home page includes title of entry, names, division (Junior or Senior), and category (Web Site), and navigation menu
- ✓ Site URL is submitted by the established deadline
- ✓ Includes process paper of no more than 500 words
- ✓ Includes annotated bibliography, separated into primary and secondary sources
- ✓ Annotated bibliography and process paper are integrated into the web site
- ✓ Presentation of topic is creative, original, and well organized
- ✓ Clearly links topic to theme
- ✓ Demonstrates significance of topic in history
- ✓ Historically accurate
- ✓ Shows interpretation and analysis
- ✓ Places topic in historical context
- ✓ Shows wide research and use of primary sources
- ✓ Provides evidence of balanced research (multiple perspectives)
- ✓ Has followed copyright laws

Category Rules – Individual and Group 2-Dimensional Display (DIS)

The 2-Dimensional Display is a scaled-down version of the exhibit category. This entry category is available only to participants in the Elementary Division. Many states offer a special category to introduce students to the History Day program. This California-only category is not included at the National History Day contest. A 2-Dimensional Display provides the opportunity to demonstrate your understanding of the topic and theme, effectively use a combination of quotations and your own words to share the context, your thesis statement and evidence that supports it, and the significance of your topic in history. You will also use images of all kinds (e.g., photos, maps, art images, etc.) and meaningful captions and labels to tell your story and guide the viewer through your display. Each 2-D display includes a process paper and annotated bibliography.

In addition the rules below, Rules for All Categories apply to 2-Dimensional Displays.

Rule DIS-1: Size and Shape: Your 2-D Display will be a rectangle no larger than 30" x 40" in size. It may be oriented either as portrait or landscape.

Rule DIS-2: Construction: Your project must be flat. It will contain no protruding elements. The display backing may be cardboard, mat board, poster board, foam board, or other flat material. You may attach flat paper items such as written materials, decorative paper, images, labels, etc. to your display backing. However, you may not raise these materials by mounting them on any material that causes them to protrude – they must lie flat on your backing. Do not use ribbon, buttons, or other materials that result in a raised or textured surface.

Rule DIS-3: Word Limit: A limit of 350 words applies to all text created by the student that appears on, or as part of, a 2-D display entry. This includes the text you write for titles, subtitles, captions, graphs, and timelines where you use your own words. Brief citations crediting the sources of illustrations or quotations included on the exhibit do not count toward the 350 student-composed word limit. This word limit does not apply to your process paper and annotated bibliography.

NOTE: A date counts as one word, while each word in a name is individually counted. For example, January 1, 1900 counts as one word, but John Quincy Adams counts as three. Words such as "a," "the," and "of" are counted as one word each.

2-Dimensional Display Checklist

- ✓ Researched and developed by Elementary Division participant(s) only
- ✓ Rectangular in shape and no larger than 30" x 40"
- ✓ Flat
- ✓ Does not exceed 350 student-composed words
- ✓ Includes required written materials prepared in accordance with citation and style guidelines (see Rules 15 & 16)
- ✓ Title page includes title of entry, name(s), division (Elementary), and category (2-Dimensional Display) only
- ✓ Annotated bibliography, separated into primary and secondary sources
- ✓ Title page, Process Paper, and annotated bibliography stapled at the top left corner
- ✓ Uses images, labels, captions, and text to create a display with visual impact and tell an interesting story to the viewer
- ✓ Shows interpretation and analysis
- ✓ Places topic in historical context and is historically accurate
- ✓ Demonstrates wide research and use of primary sources
- ✓ Project reflects balanced research (multiple perspectives on the topic)
- ✓ Shows the connection between the topic and the theme
- ✓ Explains why the topic is significant in history
- ✓ Follows copyright laws

Entry Judging

The National History Day program at every level is about a high quality educational experience, whether or not you win a prize. Judges provide evaluations to validate your hard work and to help you continue to learn and develop your skills. Judges' comments will include positive feedback as well as ideas for revisions and enhancements. This feedback may be applied during the current year when moving from one contest level to the next and/or to next year when developing a new entry. Rules and criteria as well as the judging process help you focus on high quality project development based on research, analysis and interpretation, creativity, effective writing, time management, and interpersonal communication. The skills you develop will last your entire life. While the medals are nice, truly, every participant is a winner.

Who are the Judges?

Historians, educators, and others interested in history and education serve as judges in the NHD-CA State Finals. In addition to providing each participant with valuable feedback, judges tackle the daunting task of determining the entries that will represent California at the NHD National Finals. Each year, NHD-CA seeks out additional new judges from sources including NHD alumni, university professors, and students. We invite individuals interested in judging to contact NHD-CA through our web site at ca.nhd.org.

How does the Evaluation Process Work?

Judging Panels: A panel consisting of two-to-three judges evaluates a set of entries from a specific division and entry category (e.g., Senior Individual Performance). Considerations in panel composition include judges' preferences, possible conflict of interest, history day experience, gender, and background. Judges attend an orientation session before the process begins.

Rounds of Judging: In categories with a large number of entries, the entries are separated into manageable sets. In this case, determination of champion entries requires two rounds of judging: Round One to determine finalists, and Round Two (Finals Round) to determine champions. The number of entries in each set varies by category, and is completely within the discretion of contest officials.

Consensus Judging: Judges follow a non-numerical, consensus (agreement) process. Each judge completes an evaluation form and is highly encouraged to provide helpful feedback. After reviewing the entries in a set, the judges adjourn to discuss the merits of each entry with an emphasis on the Historical Quality aspect of each. They collectively determine the entries that will advance to the next level of competition.

The Subjective Nature of Judging: While some elements of entries may be evaluated objectively (e.g., time/word limit adherence, use of primary sources, inclusion of an annotated bibliography, correct spelling, etc.), much of an entry is subjectively assessed (e.g., analysis and conclusions about the historical data). You will want to base your interpretations and conclusions on solid research, provide a clear contextual foundation for your topic, highlight the connection between your topic and the theme, overtly state your thesis, clearly show different points of view, and clearly articulate the significance of your topic in history.

Judges' Decisions: Individual judges' evaluation sheet ratings and comments can vary tremendously. It is possible that an entry that receives high marks from one panel of judges will not be declared a winner while an entry evaluated by a different judging panel with lower marks may advance to the next level of competition. This reflects the subjective nature of judging as well as the consensus process. Contest officials wish to be informed of possible problems or errors that may have occurred. However, the *decision of judges is final*. Judges are instructed not to discuss their decisions outside their panel. Participants, parents, and teachers shall not approach or question judges regarding their decisions.

Judging Historical Paper and Web Site Entries: Adequate evaluation of entries in these categories requires early submission. Judges review Historical Paper and Web Site entries prior to the contest and conduct interviews and reach consensus during the competition.

Evaluation Tools: Each judge completes an evaluation sheet for each entry s/he judges. NHD-CA evaluation sheets align closely with NHD score sheets. The key difference is that NHD-CA evaluation sheets include six columns per rated item to provide students with nuanced developmental feedback regarding areas of excellence and growth to help them improve their current and future projects. NHD evaluation sheets include four columns. Students receive their evaluation sheets following the conclusion of the State Finals.

What are the Criteria?

Historical Quality (60%): The most important aspect of your entry is its historical quality. You should ask yourself the following questions to help you focus on your historical analysis:

- Is my entry historically accurate?
- How well does my entry provide analysis and interpretation of the historical data rather than just provide a description?
- How well does my entry explain the historical context?
- How well does my entry demonstrate understanding of both the cause(s) and effect(s) of my topic?
- How well does my annotated bibliography demonstrate wide research?
- How well does my entry demonstrate a balanced presentation of materials?
- How well does my entry demonstrate use of available primary sources?
- How well does my entry demonstrate that I understand the difference between primary and secondary sources?

Relation to Theme (20%): Your entry must explain clearly the relation of your topic to the annual National History Day theme. You should ask yourself the following questions to help focus your topic on the theme and its significance.

- How does my topic relate to the theme?
- Why is my topic important?
- How is my topic significant in history and in relation to the National History Day theme?
- How did my topic influence history?
- How did the events and atmosphere (social, economic, political, and cultural aspects) of my topic's time period influence my topic in history?

Clarity of Presentation (20%): Although historical quality is most important, your entry must be presented in an effective manner. You should ask yourself the following questions to help you focus on your presentation.

- Does my entry stay within the time/word and other constraints for my entry category?
- Is my entry original, creative, and imaginative in subject and presentation?
- Is my written material clear, grammatically correct, and accurately spelled?
- Is my entry well-organized?
- Do I display stage presence (in a performance)?
- Are my props and costumes appropriate (in a performance)?
- Is the visual material I present clear?
- Do I understand and properly use all of my equipment?

Judges will take into consideration in their final rankings any rule infraction. Failure to comply with the rules will count against your entry. Rule infractions should be corrected before a winning entry competes in the next level of competition.

Going to the State Finals

If selected to represent your county at the NHD-CA State Finals, you will need to register online and pay registration fees by the due date. Information about the venue, lodging, and the registration process will be available in mid-February. Completion of the online registration process includes the following confirmations:

1. Agreement to a **Code of Ethics Statement** affirming that you developed your entry during the current contest year and that all aspects of the research, analysis, design, project development, writing, etc. were done by the student(s) entering the competition
2. Parent/Guardian **Permission Slip and Liability Waiver**
3. Permission for NHD-CA to **duplicate and share your entry**

Mandatory Attendance: Evaluation at the State Finals requires registration by all students participating in the entry. Only with special prior approval from the State Director may students represent their counties but not personally attend the competition. Replacement of students unable to attend the State Finals is subject to the County Coordinator's approval. The same attendance requirement applies at the National History Day competition.

NOTE: Please check at your local level for registration and attendance requirements.